



Product Family: [Current Sensing Power Resistor](#)

Part Number Series: [CPA0612 Series](#)

	<p>Construction:</p> <ul style="list-style-type: none"> • High purity alumina substrate • Nickel alloy thin-film resistive element • Epoxy-resin overcoat • Pre-tinned (Sn100, matte) terminations over Ni barrier is standard (RoHS compliant and Pb Free) 	<p>Features:</p> <ul style="list-style-type: none"> • TCR = ± 50 ppm/$^{\circ}$C • Power up to 1 watt • RoHS compliant (Pb Free) and Halogen Free • High volume production suitable for commercial and special applications
--	--	--

Description:
 These thin film, low resistance, high power chip resistors exhibit excellent performance in resistance, noise performance, surface heat distribution and have a lower surface temperature. They are useful in many current sensing applications.

Product Dimensions:

	<table border="1"> <thead> <tr> <th>Dimension</th> <th>Specification</th> </tr> </thead> <tbody> <tr> <td>L</td> <td>0.063 \pm 0.008</td> </tr> <tr> <td>W</td> <td>0.126 \pm 0.008</td> </tr> <tr> <td>t</td> <td>0.020 \pm 0.006</td> </tr> <tr> <td>S1</td> <td>0.094 \pm 0.006</td> </tr> <tr> <td>S2</td> <td>0.020 \pm 0.006</td> </tr> <tr> <td>S3</td> <td>0.012 \pm 0.006</td> </tr> </tbody> </table>	Dimension	Specification	L	0.063 \pm 0.008	W	0.126 \pm 0.008	t	0.020 \pm 0.006	S1	0.094 \pm 0.006	S2	0.020 \pm 0.006	S3	0.012 \pm 0.006	<table border="1"> <thead> <tr> <th>Dimension</th> <th>Specification</th> </tr> </thead> <tbody> <tr> <td>B1</td> <td>0.102 \pm 0.008</td> </tr> <tr> <td>B2</td> <td>0.012 \pm 0.004</td> </tr> <tr> <td>B3</td> <td>0.012 \pm 0.006</td> </tr> <tr> <td>B4</td> <td>0.024 \pm 0.008</td> </tr> <tr> <td>B5</td> <td>0.016 \pm 0.004</td> </tr> <tr> <td>B6</td> <td>0.008 \pm 0.006</td> </tr> </tbody> </table>	Dimension	Specification	B1	0.102 \pm 0.008	B2	0.012 \pm 0.004	B3	0.012 \pm 0.006	B4	0.024 \pm 0.008	B5	0.016 \pm 0.004	B6	0.008 \pm 0.006
Dimension	Specification																													
L	0.063 \pm 0.008																													
W	0.126 \pm 0.008																													
t	0.020 \pm 0.006																													
S1	0.094 \pm 0.006																													
S2	0.020 \pm 0.006																													
S3	0.012 \pm 0.006																													
Dimension	Specification																													
B1	0.102 \pm 0.008																													
B2	0.012 \pm 0.004																													
B3	0.012 \pm 0.006																													
B4	0.024 \pm 0.008																													
B5	0.016 \pm 0.004																													
B6	0.008 \pm 0.006																													

Note: All dimensions in inches

Product Construction & Marking: (refer to callouts in diagram above)

- 1 = Substrate (96% Alumina)
- 2 = Resistor Film (Ni Alloy)
- 3 = Terminals (100% Matte Sn)
- 4 = Protection Coating (Epoxy Resin)
- 5 = Marking (Epoxy Resin)

Marking will consist of the 4-digit resistance code as detailed in the part numbering section

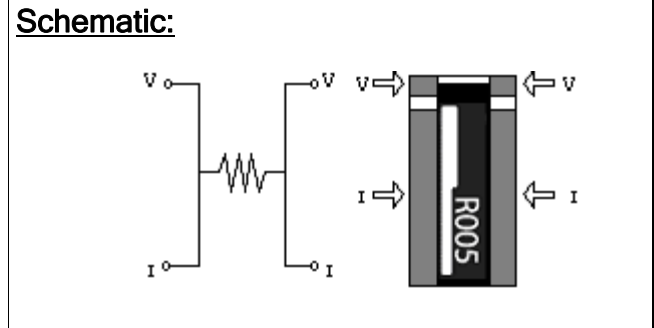

Part Numbering: CPA0612QR005FS* (*Note: T&R package quantity (-T50) will be appended by us to the end of the part number)

Product Designator	Ceramic Type	English Size (Metric Size)	Temp. Coefficient of Resistance (TCR)	Resistance Value *	Tolerance	Custom Code
CP	A = Alumina	0612 (1632)	Q = ± 50 ppm/ $^{\circ}$ C	Ex. R005 = 0.005 Ω	F = $\pm 1\%$	S = Standard

*Note: For resistance values with single milliohm increments, use "R" to specify the decimal point (i.e. R005=0.005 Ω). For resistance values with 1/2 milliohm increments, use "M" to specify the decimal point. For products under 10 milliohm, the "M" will be in the second position (i.e. 7M50 = 7.50m Ω), and for products above 10 milliohms, the "M" will be in the third position (i.e. 10M5 = 10.5m Ω).

Electrical Specifications:

Type	CPA0612-FS
English Size	0612
Metric Size	1632
Power	Up to 1 watt
Rated Voltage	$\sqrt{\text{Power} \times \text{Resistance}}$
Resistance Tolerance	$\pm 1\%$
Standard Resistance Values	0.005 Ω , 0.007 Ω , 0.0075 Ω , 0.010 Ω , 0.020 Ω
TCR ppm/ $^{\circ}\text{C}$ (code)	$\pm 50\text{ppm}/^{\circ}\text{C}$ (Q)
Operating Temperature	$-40^{\circ}\text{C} \sim +125^{\circ}\text{C}$
Maximum Over Current	45A, 10msec, 10 times Interval of 60 seconds minimum
Packaging	5,000 pcs/reel

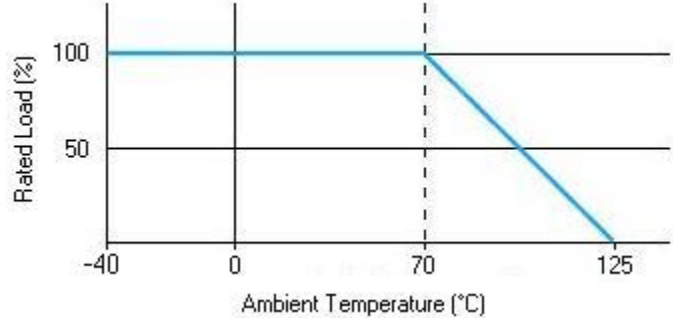
CPA0612 Derating Curve:**Reliability Specifications:**

Test	Test Method	Specification
Short Time Overload	Applied voltage: 1.5X rated voltage. Test duration: 5 seconds	$\pm 0.5\%$
Load Life	Test Temperature: $70^{\circ}\text{C} \pm 3^{\circ}\text{C}$ Applied voltage: rated voltage Test period: 1000 hours with power cycling as follows: 90 min. power ON/30 min. power OFF,	$\pm 1.0\%$
Moisture Load Life	Test Condition: $60^{\circ}\text{C}/90\% \text{RH}$ Applied voltage: rated voltage Test period: 1000 hours with power cycling as follows: 90 min. power ON/30 min. power OFF	$\pm 1.0\%$
Temperature Cycle	Repeat 5 cycles as follows: -40°C (30 min.) / Room temp (3 min) / $+125^{\circ}\text{C}$ (30 min.) / Room temp (3 min)	$\pm 0.5\%$
Resistance To Solder Heat	Dipped into solder for 10 ± 1 seconds at $260 \pm 5^{\circ}\text{C}$	$\pm 0.5\%$
Substrate Bending	Span between fulcrums: 90mm Bend Width: 2mm Test Board: Glass Epoxy $t = 1.6\text{mm}$	$\pm 1.0\%$
Solderability	Dipped into solder for 3 ± 0.5 seconds at $245 \pm 5^{\circ}\text{C}$	New solder coverage of 90% minimum

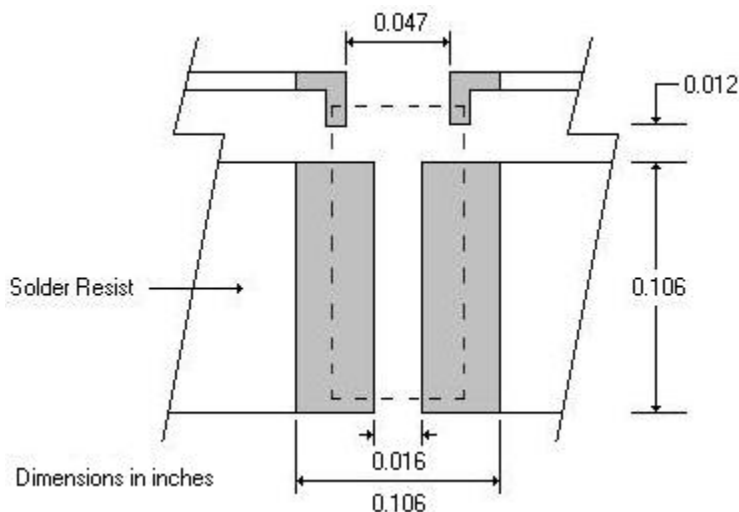
Recommended Land Pattern for Current Sensing:**Notes:**

- 1) Board material: Glass epoxy (FR4), 24 mil board thickness, 4 mil copper thickness
- 2) Board surface temperature shall not exceed 100°C when applying rated wattage

Taping Diagrams:

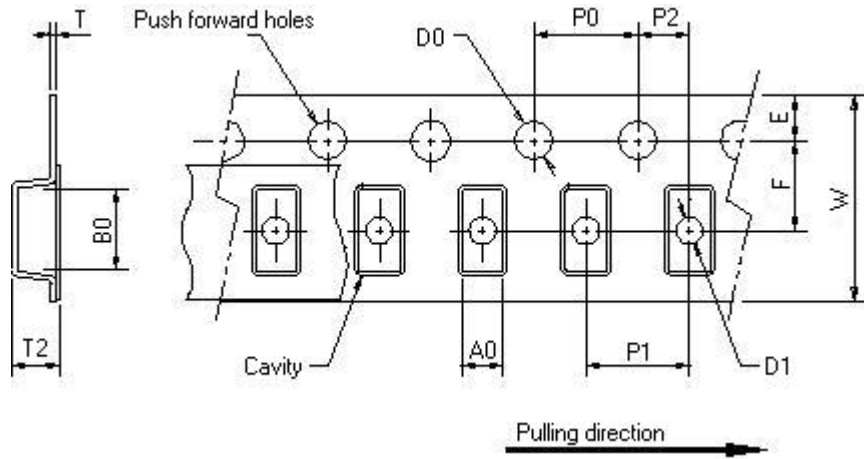

Symbol	Dimensions (inch)
A0	0.075 ±0.004
B0	0.138 ±0.004
W	0.315 ±0.008
F	0.138 ±0.002
E	0.069 ±0.004
P0	0.157 ±0.004
P1	0.157 ±0.004
P2	0.079 ±0.002
D0	0.061 ±0.002
D1	0.041 ±0.002
T	0.008 ±0.002
T2	0.039 ±0.008

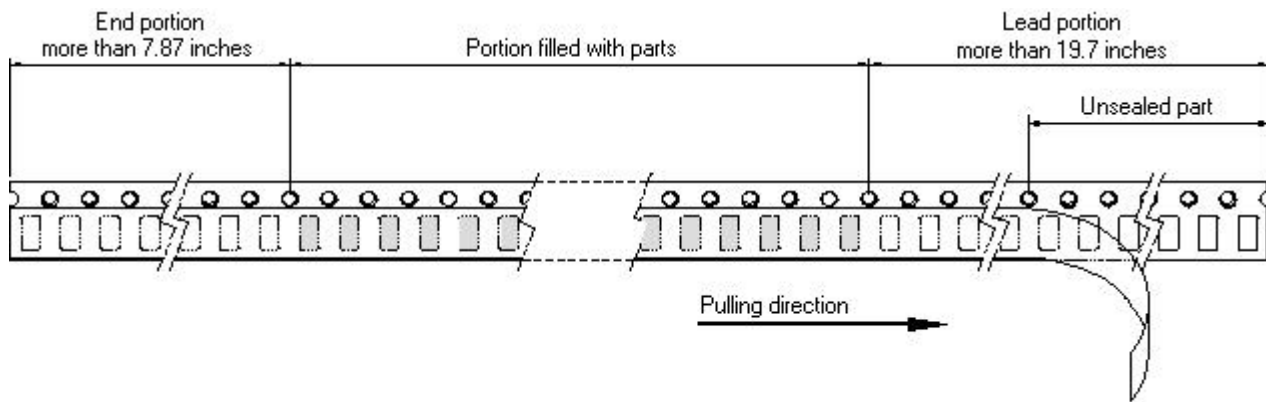

Reel - Labeling Position:

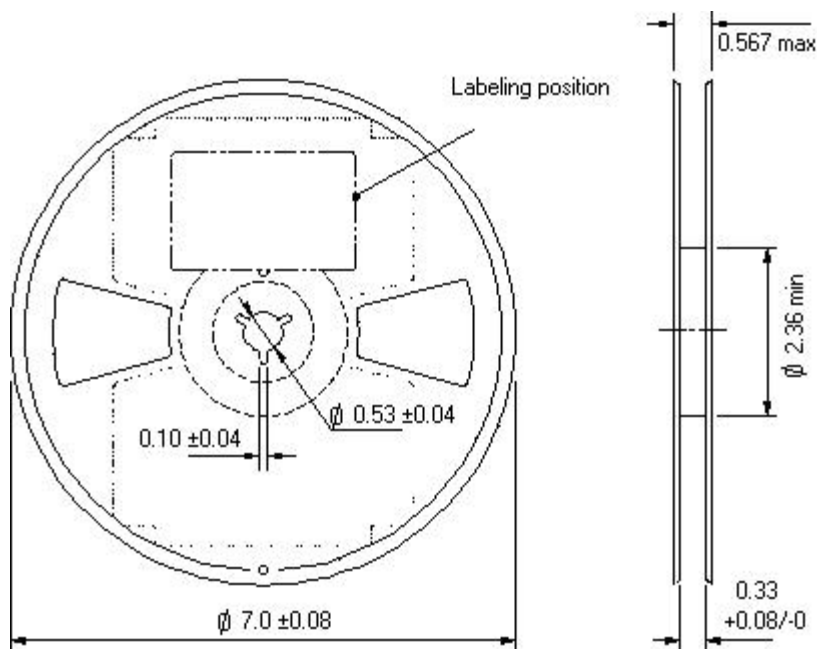

(Unit = inches) Material = Plastic

Taping Direction:

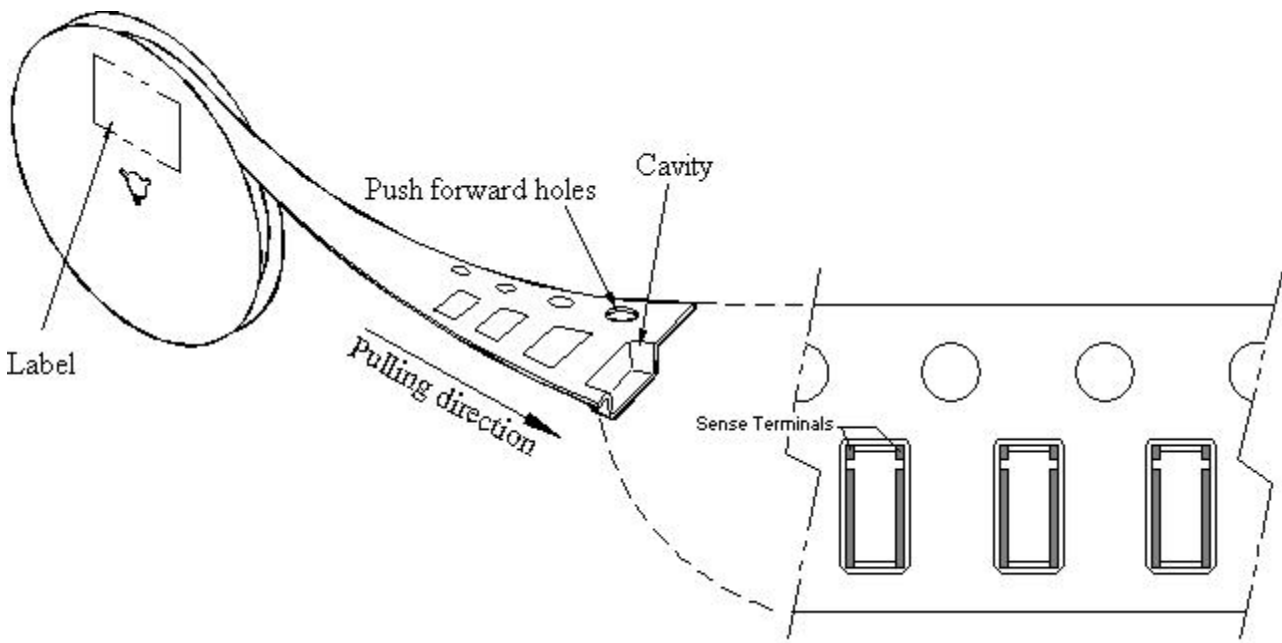

Recommended Soldering Profile:

SOLDERING PROFILE

Profile Feature	Pb-Free Assembly
Average Ramp-Up Rate ($T_{s_{max}}$ to T_p)	3 °C/second max.
Preheat	
- Temperature Min ($T_{s_{min}}$)	150 °C
- Temperature Max ($T_{s_{max}}$)	200 °C
- Time ($t_{s_{min}}$ to $t_{s_{max}}$)	60-180 seconds
Time maintained above:	
- Temperature (T_L)	217 °C
- Time (t_L)	60-150 seconds
Peak Temperature (T_p)	260 +0 °C
Time within 5 °C of actual Peak Temperature (t_p)	20-40 seconds
Ramp-Down Rate	6 °C/second max.
Time 25 °C to Peak Temperature	8 minutes max.

